

3-MOTOR 4-HEAD
TAPE DECK

RT-909

OPERATING INSTRUCTIONS

KU
KC

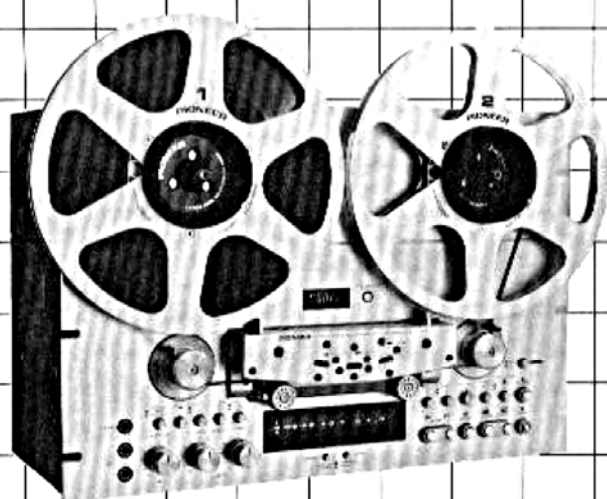

CONTENTS

Precautions	2
Features	3
Front Panel Facilities	4
Connections	7
Installation Precautions	7
Threading the Tape	8
Basic Operations	9
Playback	11
Auto Reverse	12
Auto Repeat	13
Recording	14
Microphone Recording	17
Other Methods of Recording	18
Rack-mounting	19
Operations with the Timer	20
Handling Tapes	21
Care and Maintenance	22
Specifications	23
Troubleshooting	24
Schematic Diagram	Insertion

IMPORTANT NOTICE

The serial number for this equipment is located on the opposite panel on the controls.
Please write this serial number on your enclosed warranty card and keep in a secure area. This is for your security.

WARNING: TO PREVENT FIRE OR SHOCK HAZARD, DO NOT EXPOSE THIS APPLIANCE TO RAIN OR MOISTURE.

 PIONEER

Before operating your RT-909 TAPE DECK, please read these Operating Instructions through and then you will know how to connect the tape deck properly and operate the tape deck correctly. This will ensure that you enjoy the stereo performance to the full.

After reading these instructions, keep them in a safe place together with the warranty card. Then you will know exactly where it is in case you wish to refer to it.

PRECAUTIONS

HANDLING THE POWER CORD

- Always take hold of the plug to unplug it from the power outlet; do not unplug it by pulling on the cord. The cord may be damaged if you keep pulling on it.
- Do not handle the power cord with wet hands. This is extremely dangerous because you may get an electric shock.

PRECAUTIONS FOR USE

- Under no circumstances should the bonnet be removed, and the internal parts touched or modified in any way. Pioneer will not be held responsible in the event of a deterioration in performance or a breakdown if the tape deck is modified in any way.
- Do not bring screwdrivers and other metal objects or magnets near the heads since you may damage and magnetize them.

KEEP THE TAPE HEAD SECTION CLEAN (Fig. 1)

The sound quality will deteriorate and other unforeseen difficulties may arise if you allow the areas of the heads, capstan, pinch roller, etc., which come into direct contact with the tape, to become dusty or dirty. Before actually using the tape deck, be sure to clean the surfaces of the heads with the cleaning swabs supplied with the deck. For further details, refer to page 22 "Care and Maintenance."

TAPE REELS

- Use 10-inch or 7-inch reels. Both reels should be of the same size. If they are not, they will slow down at different rates which leads to unstable tape run.
- Do not use reels which have been deformed or warped in any way, or reels with a broad tape width. If the tape comes in contact with the side of the reel, it will be damaged.

BE SURE TO CLAMP THE REELS

After you mount the reels, make absolutely sure that you clamp both reels so that they will not separate themselves from the bases during tape play (Refer to Fig. 2, 3).

For further details, refer to the section on "Mounting the Reels" on page 8.

Moisture forms in the operating sections of this model and the model's performance will be impaired if the model is brought from cool surroundings into a warm room or if the temperature of the room rises suddenly.

To prevent impairing performance, let the model stand in its new surroundings for about an hour before switching it on, or ensure that the room temperature rises gradually.

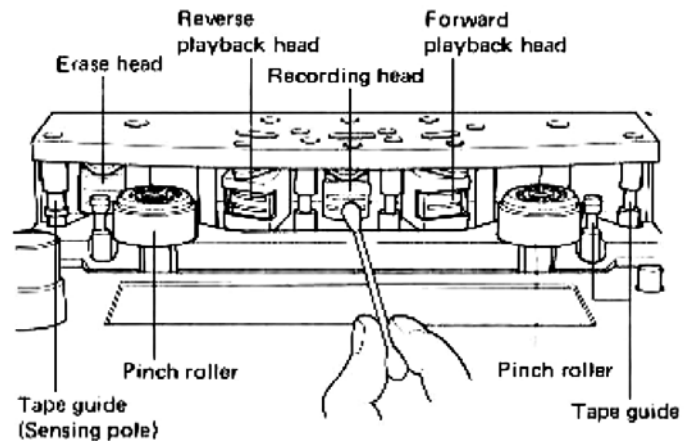

Fig. 1

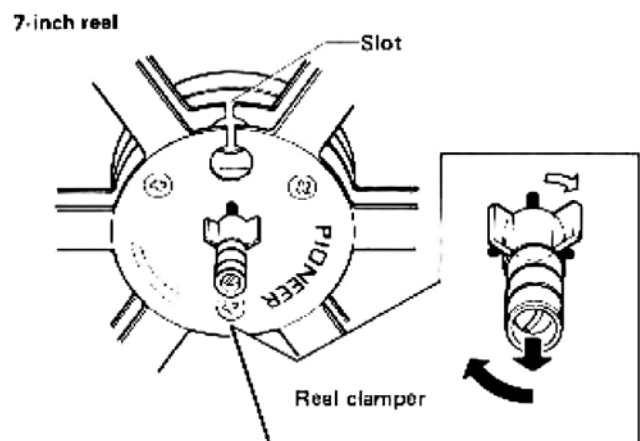

Fig. 2

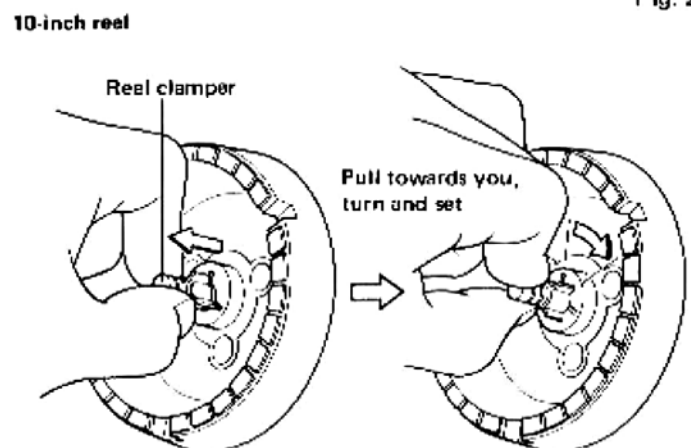

Fig. 3

FEATURES

Auto Reverse, Auto Repeat Mechanisms

The RT-909 with its four heads has a sensing tape auto reverse mechanism for return playback (material is recorded in one direction only). This allows recorded programs to be played back automatically over long periods of time without the tape being changed over or rewound manually. Also, there is an auto repeat mechanism (repeat button) which employs the tape deck's tape counter. The sensing tape and the repeat button are used together for repeated automatic playback.

Feather-Touch Tape Function Buttons Using LSI Logic Control Circuitry

The adoption of single-packaged IC logic control circuitry makes it possible to select the tape travel in a smooth feather-touch operation. Even when switching from the fast forward or rewind mode to the playback mode, the tape is not damaged in any way and the switchover is both direct and speedy. Another big feature is the LSI-stored program which deals with faulty operation and duplicated depressing of the function buttons and which puts the tape automatically through the stop mode when necessary during switch-over.

Symmetrical Tape Transport System with Closed Loop Dual Capstan

The perfectly symmetrical left and right tape transport mechanisms enable the tape transport characteristics to display the same superb values whether the tape is traveling in the forward or reverse direction. Under the closed loop dual capstan system, a capstan is positioned at the left and right of the heads to maintain a stable head-to-tape contact at all times. This configuration enables the external vibrations which are generated outside the loop and which are transmitted to the tape from the supply side or the take-up reel to be suppressed and the modulation noise to be cut down as well as an admirable wow/flutter to be preserved.

Frequency Generator (FG) Servo DC Motor

A frequency generator servo DC motor is employed and the generator serves to detect the rotational speed. Any deviation from the rated rotational speed is detected by this frequency generator as a frequency component and the motor speed is controlled. The result is that the speed maintains a high level of precision and the speed drift (wow/flutter) is kept down to 0.04% (WRMS). The highly precisioned capstans and the dynamically balance flywheel combine to provide a smooth rotation.

Electromagnetic Brake to Preserve the Tape and Display a Fast Response Speed

In order to reduce the adverse effects of the inertia of the rotating tape, an electromagnetic brake is adopted. This is used along with a mechanical brake for selecting the tape travel mode and stopping the tape. This feature, together with the full logic controls, allows the deck to be set from one mode to another directly without straining the tape whatever the mode.

Highly Precisioned Guide Roller and Tension Arm Mechanism for Protecting the Tape

The oil-damped tension arm with its directionality absorbs the sudden variations in the tape travel. When the tape is loaded, the tension arm is locked and this allows the tape to be threaded inside easily. The guide roller, which is engineered to a high degree of precision, reduces undesirable wear when the tape is sent forward or rewound at high speed, it helps protect the tape and also reduce the strain on the mechanism.

Digital Bar-Graph Fluorescent Display Meter

The level meter features all-electronic digital control and bar-graph fluorescent display tubes. The length of the bars are made to correspond to the strength of the signals supplied both for the left and right channels in parallel. This makes it easy to set the recording level accurately.

4-Digit Tape Counter

The tape counter is all-electronic thanks to a built-in IC which detects the rotation of the reel base in pulses and displays them on the 4-digit fluorescent display tube.

Tough and Reliable Construction

The tape deck's construction combines a 5mm-thick front panel and a diecast frame for the outer casing to protect the heavy inside parts. The construction is designed to display the maximum precision and durability, and the front panel can be mounted in a rack conforming to EIA standards.

Convenient Accessory Function

PITCH CONTROL knob: This control is used to change the rated tape speed during playback (19cm/s, 9.5cm/s) across a $\pm 6\%$ range — in other words, the tape can be made to go 6% faster or slower.

Musical steps can be raised or lowered as far as the semitones. This means that you can bring the steps of the recorded music into line with the steps of the instrument which you are playing. This control is therefore useful when you are using a tape for song accompaniments.

REC MODE button: Program sources can be recorded not only in stereo, but also in mono using the left or right channel only. This button allows you to use your recording talents and techniques to the full whether you want to record mono signals over a prolonged period of time, dabble with mixing recording or try out sound-on-sound recording. It gives you a range of possibilities that you would expect from the top-top RT-909.

MIC/LINE Mixing Recording

You can mix the sound of a microphone with the sound of a program source such as a record or an FM program, and record the mixed sound.

Unattended Recording and Wake-up Playback

If you use the deck with an optional timer, you can record programs off your tuner unattended and wake up to music from the deck instead of being woken up by an alarm clock.

FRONT PANEL FACILITIES

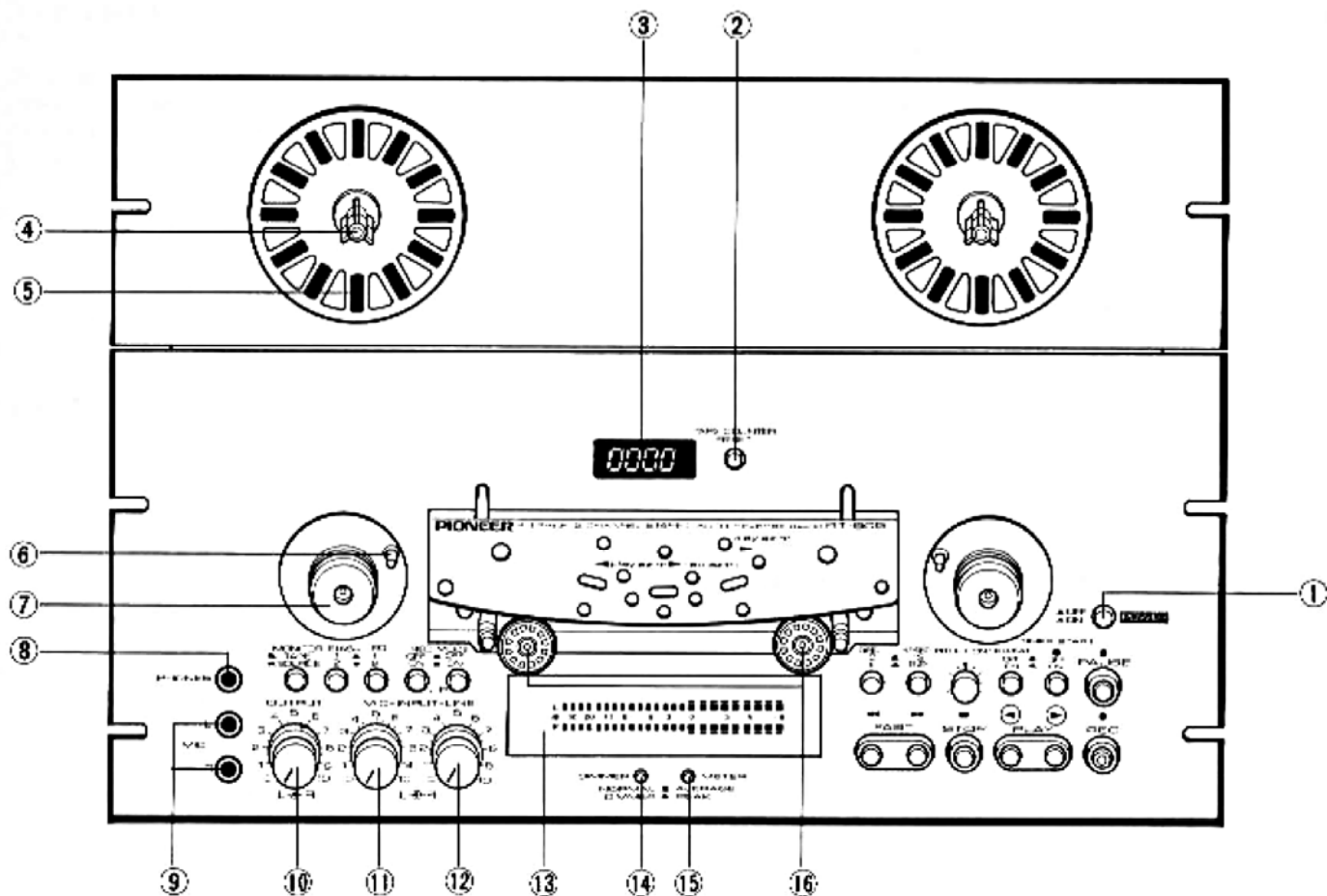

① POWER SWITCH

The power comes on when the POWER switch is depressed. The level meter and tape counter, will then come on. Release to turn the power off.

② COUNTER RESET BUTTON

Push this button to reset the tape counter to "0000."

③ TAPE COUNTER

This indicates how much tape has been recorded or played back and how much there is left over.

④ REEL CLAMPER

⑤ REEL BASE

⑥ TENSION ARM

Push down the arm and lock it while threading the tape. Release the lock after the tape has been threaded.

⑦ GUIDE ROLLER

⑧ HEADPHONE JACK

Plug your stereo headphones into this jack to hear the sound from the signals selected by the MONITOR switch. Use headphones to monitor a recording or listen to a performance directly taped from the RT-909. The output level of the headphones can be adjusted by the OUTPUT level controls.

NOTES:

- Please use low impedance-type headphones. If you use high impedance-type headphones, you may not obtain sufficient volume.
- Do not connect a microphone to this jack, as the microphone may be damaged.

⑨ MIC JACKS (L, R)

These are the input jacks for microphone recording. The L (left) and R (right) channels can be used independently. As long as the microphones have a standard 6mm diameter plug, you can use either a low impedance (600-ohms) or high impedance (10 – 50 kohms) type.

⑩ OUTPUT CONTROLS

Use these controls to adjust the output signal level. Turning the controls to the right increases the level. The controls are coupled when turned but it is also possible to adjust the right channel (outer) and the left channel (inner) independently. When playing back a reference tape, a reference playback level (0dB) is obtained with these controls set to the center click stop position.

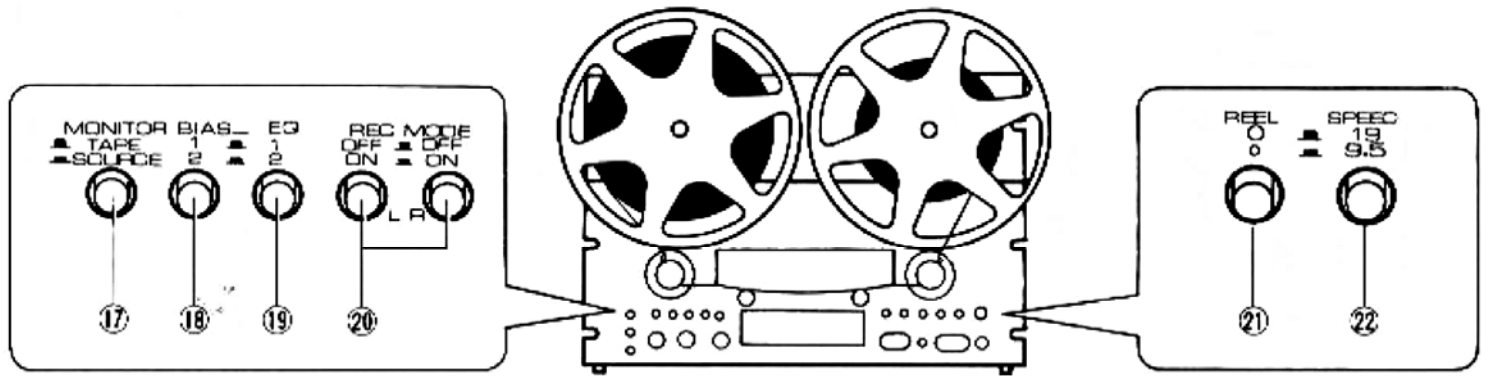

11 MIC-INPUT (RECORDING LEVEL) CONTROLS

Use these controls to adjust the recording level when you are recording with a microphone (or microphones). Use the inner control for the left channel and the outer control for the right channel.

12 LINE-INPUT (RECORDING LEVEL) CONTROLS

These controls adjust the recording input level from the LINE INPUT terminals on the rear panel. The level increases as the controls are turned to the right. The inner control is for the left channel and the outer control for the right channel.

13 FL METER

This indicates the input level during recording and the output level during playback.

By operating the METER switches, it can be made to function as a peak meter, or as a (AVERAGE) meter.

The input signal level is indicated when the MONITOR switch has been depressed, and the playback output level is indicated when the MONITOR switch has been released.

14 DIMMER SWITCH

Use this switch to select the brightness of the level meters and tape counter.

NORMAL (⬆): When using the tape deck in daylight or other bright locations.

DIMMER (⬇): At night or in dark locations when the existing brightness is too high.

15 METER SWITCH

AVERAGE (⬆): When the switch is released to AVERAGE, the meter functions as an ordinary level meter.

PEAK (⬇): When this switch is depressed to PEAK, the meter functions as a peak meter.

16 PINCH ROLLER

17 MONITOR SWITCH

This switch is used to select the output signal which is made available at the output and headphone jacks. Since the indication of the level meter can be switched over at the same time, always make it a rule to depress this switch when adjusting the recording level (set to SOURCE position).

For playback: Set the switch to the released (TAPE) position. If it is set to the depressed (SOURCE) position, you will not be able to hear the playback sound.

For recording: Set the switch to the released (TAPE) position and you will then be able to hear the signals (playback sound) immediately after you have recorded the sound source.

If the switch is set to the depressed (SOURCE) position, you will be able to hear the signals (recording input) immediately before you record the sound source.

18 BIAS SWITCH

This selects the recording bias current according to the type of tape used for recording. Push for 2; released for 1.

1: For standard tapes.

2: For low noise and high output tapes.

19 EQ SWITCH

This selects the recording equalization characteristics according to the type of tape used. Push for 2; released for 1.

1: For standard tapes.

2: For low noise and high output tapes.

(For further details on how to use the BIAS and EQ switches, refer to the "BIAS and EQ Switches" on page 16).

20 REC MODE SWITCHES (L, R)

Make absolutely sure that these switches are depressed and set to ON for recording.

L: For recording on the left (L) channel.

R: For recording on the right (R) channel.

Depress both switches (L and R) for stereo recording. Do not select these switches during actual recording.

21 REEL SIZE SELECTOR

Set this selector to the corresponding to the size (diameter) of the reel being used.

○ mark: Set the switch to the depressed position when using a 7-inch (17cm) reel.

○ mark: Set the switch to the released position when using a 10-inch (26cm) reel.

NOTES:

• Always use two reels of the same size.

• Do not use reels with a diameter of 5 inches (12cm) or less.

22 SPEED SWITCH

This switch selects the tape speed. Push for a 9.5cm/s speed; release for a 19cm/s speed (released position).

⬆ 19cm/s: Used for recording music programs, etc.

⬇ 9.5cm/s: Used for recording lengthy conversations, etc.

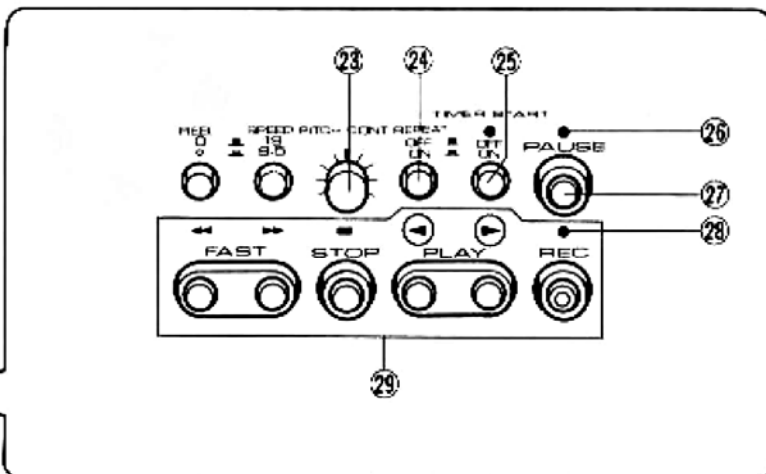
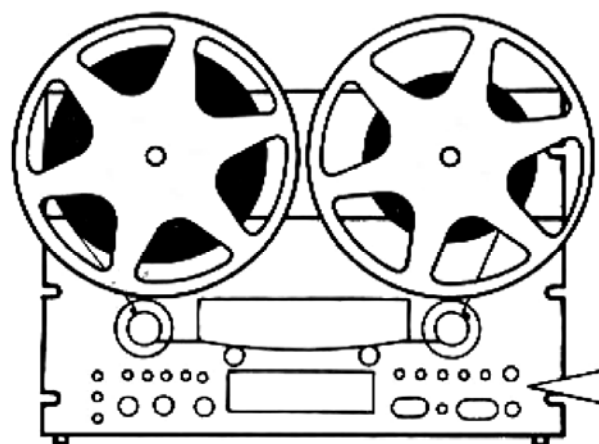

23 PITCH CONTROL KNOB

You can use this to make the tape travel 6% faster or slower than the normal tape speed during playback. When set to the central position (▼), the tape speed is 19cm/s or 9.5cm/s (standard values). Turn the control to the left and the speed drops and the musical steps are lowered; conversely, turn it to the right, and the speed rises and the musical steps are raised. This control cannot be used during recording.

24 REPEAT BUTTON

This button allows you to reverse the tape forward for reverse playback automatically. If you remember to work the tape counter and REPEAT button, then the tape will automatically be reversed and the tape deck will be set to forward playback when the "0000" display on the tape counter gives way to "9999" during reverse playback. For details, refer to the section "Auto Repeat" on page 13. Be sure to release this button when you do not require repeated playback.

25 TIMER START SWITCH

When unattended recording or wake-up playing back a tape with the help of a timer, depress this switch and then select the REC MODE switches as in the table below. When this switch is set to ON, the green indicator will come on. For details, refer to "Operations with the timer" on page 20. The TIMER START switch works only when the tape is traveling in a forward direction.

Application	TIMER START switch	REC MODE switch
For unattended recording	Depress to ON.	Depress L and R to ON.
For wake-up playback	Depress to ON.	Release L and R to OFF.

26 PAUSE INDICATOR

This green lamp lights up when the PAUSE button is pressed to indicate the tape has stopped temporarily.

27 PAUSE BUTTON

Depress this button to stop the tape temporarily during recording and playback. Once the button is depressed, the green indicator lights up to indicate that the deck is now set to the pause mode. Depress the button again to allow the tape to resume traveling.

This button does not work in the fast forward and rewind modes. When the fast forward (▶▶) or rewind (◀◀) button is depressed from the tape playback (forward or reverse) pause mode, the pause function is released and the tape is set to the fast forward or the rewind mode.

The pause mode can also be released with the STOP button.

28 RECORDING INDICATOR (REC)

This red lamp lights up during recording. Check that it has lit up before recording.

29 FUNCTION BUTTONS

- ◀◀ (REW): Depress this button to rewind the tape. (The tape will travel at high speed from right to left.)
- ▶▶ (FF): Depress this button to send the tape forward at top speed. (The tape will travel from left to right).
- PLAY: Depress the forward (▶) or reverse (◀) PLAY button to play back (forward playback or reverse playback) or record the tape. When this button is depressed, the lamp lights up to indicate the direction of the tape.
 - ▶ Forward playback: The tape travels from left to right.
 - ◀ Reverse playback: The tape travels from right to left.
- REC: Depress the REC button and the forward (▶) PLAY button for tape recordings (and the tape travels from left to right). If the reverse (◀) PLAY button is depressed during recording while the tape is traveling in the forward direction, the recording mode will be released and the deck is set to the reverse playback mode.
- (STOP): Depress this button to stop the tape run and to release the operating buttons.

NOTE:

- When the shut-off switch which is coupled to the tension arm is at OFF, none of the function button indicators come on.
- All the operating buttons are released (OFF) to stop mode when the POWER switch is turned OFF.
- The tape deck will be forward mode when the POWER switch is re-depressed to the ON position.
- There is no need to press the (■) stop button if you want to change over from one function to another.

CONNECTIONS

Connect the RT-909 terminals (OUTPUT-INPUT) to the tape terminals on the receiver (or stereo amplifier) with the accessory cords. The upper terminal is for the left channel and the lower for the right channel.

If you do not connect the tape deck with the other audio equipment properly, you will hear a monotonous single-pitched hum and this will impair your recording. Take care, therefore, to connect properly.

Connections for playback: Connect the TAPE PLAY input terminals on the stereo amplifier with the OUTPUT (PLAY) terminals on the RT-909.

Connections for recording: Connect the TAPE REC output terminals on the stereo amplifier with the INPUT (REC) terminals on the RT-909.

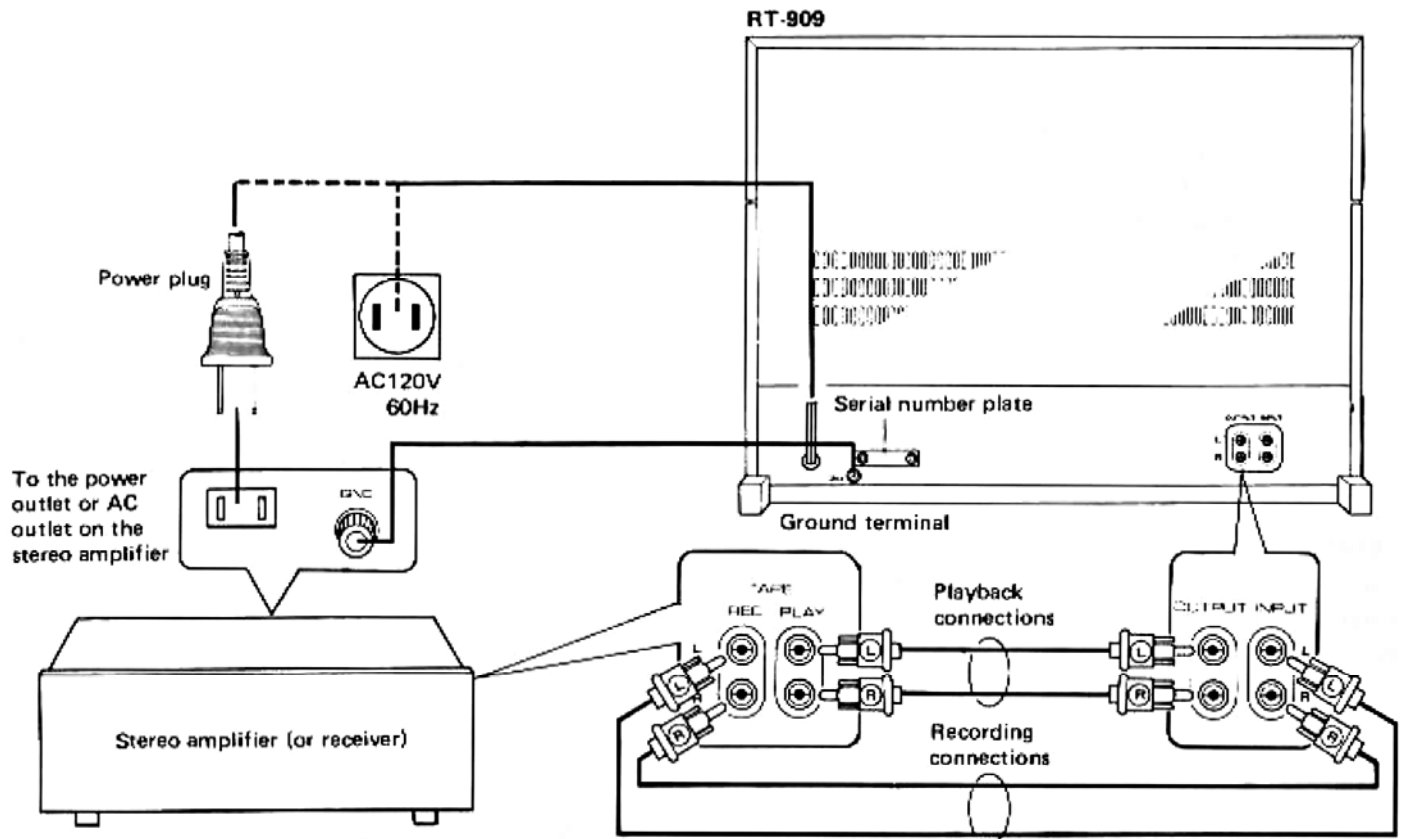

Fig. 4

INSTALLATION PRECAUTIONS

To ensure the best sound quality and trouble-free operation, avoid setting up the tape deck in any of the locations described below.

Locations liable to downgrade performance and result in breakdowns	Resulting trouble
<ol style="list-style-type: none"> 1. Locations exposed to direct sunlight, or near heaters or other heat sources. 2. Locations with poor ventilation, or with high humidity or moisture contents. Dusty locations. 3. Locations susceptible to vibration. 4. Locations where there are thinners, benzine and other types of volatile liquids; insect sprays or any kind of inflammable objects at hand. 	<ol style="list-style-type: none"> 1. External heat causes the performance of circuit parts to deteriorate, and operation becomes unstable. 2. Cause of faulty contact in input/output terminals, and of rust. High humidity and a high moisture content cause deterioration in insulation. There is also the danger of current leakage and head generation in circuit parts. Dust or grease in the rotating parts causes the parts to deteriorate. 3. These locations affect the precision parts adversely. 4. These help corrode the front panel. In particular, the heads are precision-finished to micron dimensions. Chemicals may reduce their performance, so exercise all due care.

THREADING THE TAPE

Use either two 10-inch or two 7-inch reels with this tape deck. Use reels of the same size and of the same material (use metal with metal, or plastic with plastic, for example). You may damage the tape if you use reels with different sizes and materials.

MOUNTING THE REELS

Mount the reel with the tape on the left-hand reel base and the take-up reel on the right. Make sure that the reel bases are stationary when you mount the reels and detach them.

1. Slip the reels over the bases. Simply insert with the 7-inch reels. With the 10-inch reels, however, use the accessory reel adapters (see Fig. 5) and then insert.
2. As shown in Fig. 6, pull the reel clumper towards you, rotate it to the left or right, align it with the reel or reel adapter groove, and then remove your finger.
3. Check that the reel is anchored properly.
4. Set the REEL size selector in accordance with the reel size as in the table below.

Indication	Button operation
○ mark	7-inch reel position with depressed button (▲).
○ mark	10-inch reel position with released button (■).

Threading the tape

If the tape is not provided with a leader tape, refer to "Handling tapes" on page 21 and make absolutely sure that a leader is provided.

1. As in Fig. 7, push down the left and right tension arms in the direction of the arrows and lock.
2. Draw out two turns of leader tape, thread it as in Fig. 8 and insert the end of the tape into the slot provided on the take-up reel.
3. Hold the inserted tape with your finger and rotate the take-up reel gently.
4. Rotate the left and right reels equally about three or four turns and take up the tape slack.

NOTE:

Check that the tape is not touching the edges of the reels when the reels are turned and that the reels do not move while the tape is running. If these irregularities should occur, refer to "Adjusting the height of the reel bases" and adjust accordingly.

5. Raise the left and right tape tension arms and release the lock.

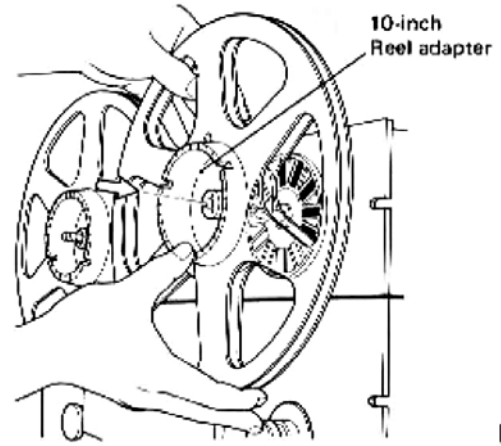

Fig. 5

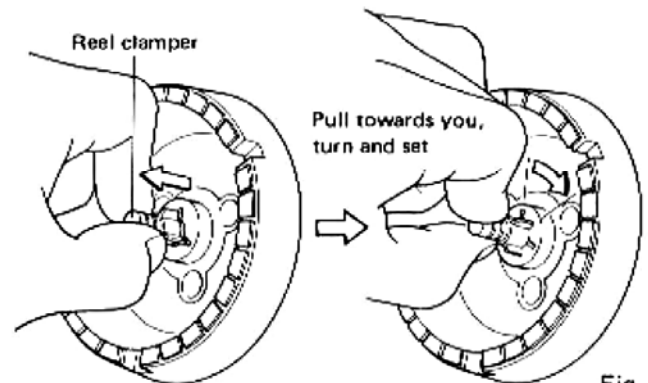

Fig. 6

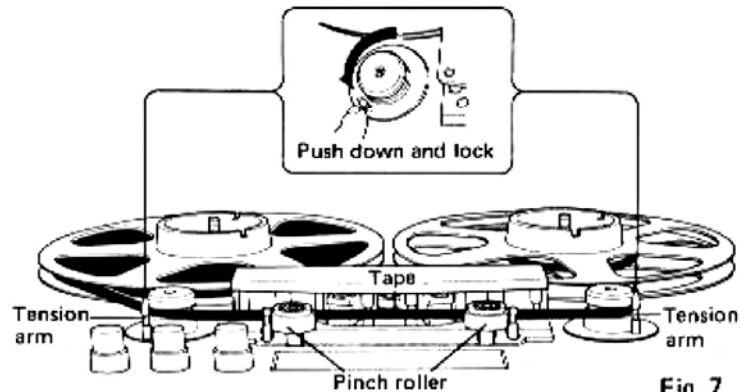

Fig. 7

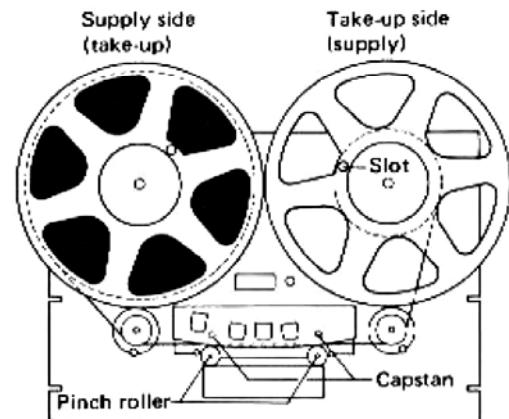

Fig. 8

Adjusting the height of the reel bases

In case of rubbing the tape against the reel edges, adjust the height of reel bases.

As in Fig. 9, hold the reel or the reel adapter with your hand and adjust the slit in the reel clamber end with an ordinary screwdriver.

- The reel base is lowered when the slit is rotated clockwise (↻).
- The reel base is raised when the slit is rotated counter-clockwise (↺).

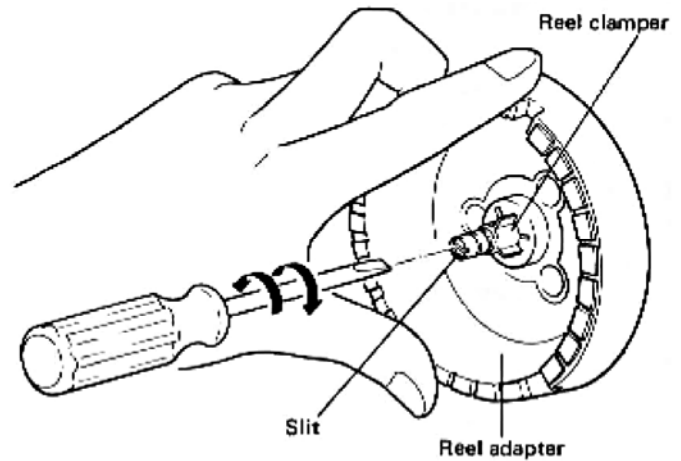

Fig. 9

SHUT-OFF MECHANISM

When the tape runs out from either reel or if it becomes slack, the tape travel is automatically stopped by the shut-off switch which is coupled to the tension arms. The switch is incorporated into the left and right tension arms and so the tape stops if both the switches are shut-off or if only one switch is shut-off.

BASIC OPERATIONS

TAPE PLAY (PLAYBACK OR RECORDING)

The tape can be played back in a forward direction from left to right, or in a reverse direction from right to left. The tape will not run in the reverse direction when you are recording.

1. First, check that the tape is on the left-hand reel for normal recording and playback.
2. When the forward **▶ PLAY** button is depressed during tape playback, the tape runs in the forward direction. If the forward **▶ PLAY** button and the recording (**REC**) button are depressed together for recording, the tape runs in the forward direction and records.
3. The tape travel direction (forward – from left to right – or reverse – from right to left) can be selected during playback with the forward **▶ PLAY** and reverse **◀ PLAY** buttons. If the reverse **◀ PLAY** button is depressed during a tape recording, the recording mode is released and the tape plays in the reverse direction.

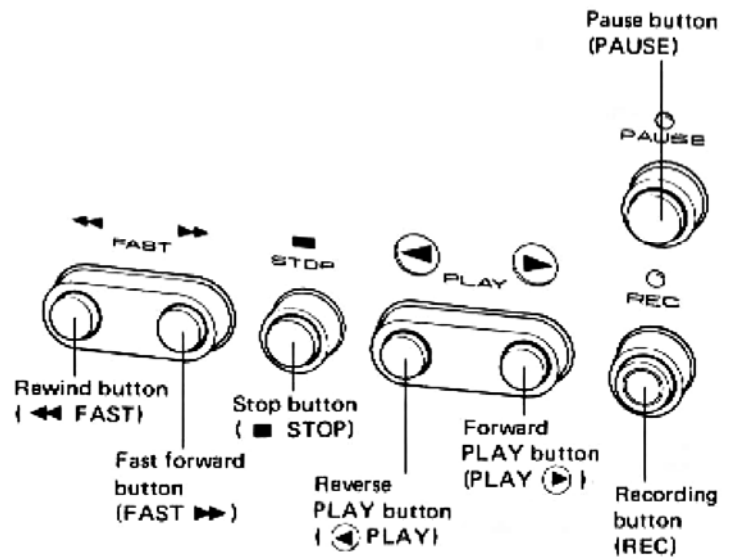

Fig. 10

STOP

Press the **■** stop button to stop the tape.

PAUSE

1. Press the **PAUSE** button while the tape is playing (during playback or recording).
2. Press the **PAUSE** button again and the tape resumes its running.

The **PAUSE** button does not work during fast forward or rewind.

FAST FORWARD

1. Check that the tape is on the left-hand reel.
2. Press the ►► fast forward button.
3. The tape is wound at a high speed from the left to the right reel.
4. Press the ■ stop button to stop the tape.
 - To return the tape deck from fast forward to tape play, press the PLAY (▶) or (◀) button. The tape stops for several seconds and then starts playing from the left (or right) to the right (or left) reel.
 - Press the ◀◀ rewind button if you have wound the tape on too far ahead. The tape is then put into reverse and it travels at a high speed from the right to the left reel.

REWIND

1. Check that the tape is on the right-hand reel.
2. Press the ◀◀ rewind button.
3. The tape is rewound at a high speed from the right to the left reel.
4. Press the ■ stop button to stop the tape.
 - To return the tape deck from rewind to tape play, press the PLAY (▶) or (◀) button. The tape stops for several seconds and then starts playing from the left (or right) to the right (or left) reel.
 - Press the ►► fast forward button if you have rewound too much tape. The tape is then put into reverse and it travels at a high speed from the left to the right reel.

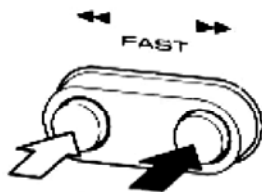

Fig. 11

NOTE:

There is no need to press the ■ stop button when changing over from one function (fast forward, for example) to another (like tape play). Just press the appropriate function button.

SETTING THE TAPE SPEED (Fig. 12)

1. Set the recording tape speed or check the playback tape speed (19cm/s, or 9.5cm/s).
2. Set the SPEED switch to the appropriate position.
 - 19cm/s: Release switch (released position ■)
 - 9.5cm/s: Press switch once (depressed position ▲)

Setting the tape speed to 9.5cm/s enables you to double the recording time, compared with a 19cm/s tape speed.



Fig. 12

TAPE TRACKS

The RT-909 is a 4-track, 2-channel tape deck. A track is the strip of the tape which is recorded (magnetized). Channel refers to the recording/playback system. First, L channel signals are recorded on track 1 and R channel signals are recorded on track 3. When the tape has been taken up and the reels changed over, the L channel and R channel signals are recorded on tracks 4 and 2, respectively. With playback, the track 1 (L channel) and track 3 (R channel) are played back in the forward direction, and the track 4 (L channel) and track 2 (R channel) are played back when the tape is reversed automatically with the auto reverse mechanism, or manually.

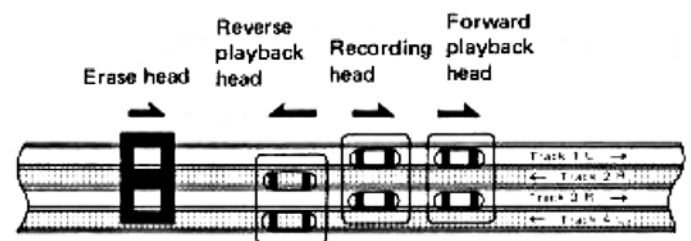

Signal vs. Track

L ₁ channel signal	Track 1
R ₁ channel signal	Track 3
R ₂ channel signal	Track 2
L ₂ channel signal	Track 4

Fig. 13

PLAYBACK

Before beginning playback, set the controls on the tape deck and the stereo amplifier as follows:

- Set the PITCH CONTROL to the center click-stop (▼) position.
- Set the FL meter switch to AVERAGE.
- Release the REPEAT button and set it to OFF.
- Release the MONITOR switch and set it to TAPE.
- Set the OUTPUT (PLAYBACK LEVEL) controls to their center click-stop positions.
- Inspect the heads, the capstans and the pinchrollers and clean them if dirty. (See page 22).
- Release the TIMER START switch and set it to OFF.
- Set the REEL size selector in accordance with the reels you are using.
- If there is any tape slack, rotate the left or right reels and stretch the tape.
- Set the stereo receiver's power switch and the TAPE MONITOR switch to ON to enable tape playback.

The numbers in the illustration correspond to the steps involved in the playback procedure.

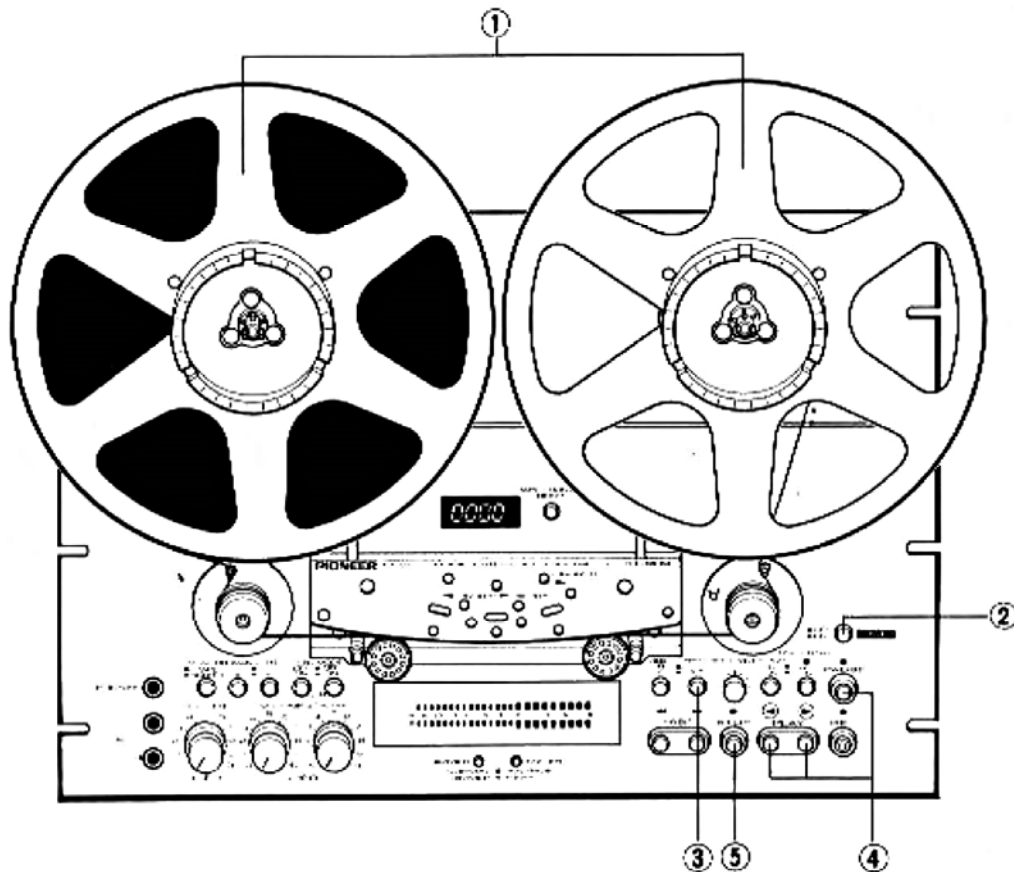

1. Attach the tape.

Attach the tape you want to play back (pre-recorded tape) to the left-hand reel base. For details, refer to "THREADING THE TAPE" on page 8.

2. Push POWER switch and turn power on.

The FL meter and tape counter light up and the capstan starts rotating as soon as the power is switched on.

3. Check the tape speed.

Decide whether the tape to be played was recorded at 19cm/s or 9.5cm/s, and set SPEED switch accordingly.

4. Depress the forward ► PLAY button.

The tape plays back in the forward direction as indicated by the PLAY button direction. The tape direction can, however, be reversed by depressing the reverse ◀ PLAY button at any time during playback. In this case, the deck is set to the pause mode for about three seconds during the selection.

The RT-909 can be set up for automatic reverse and automatic repeat. Refer to "AUTO REVERSE/AUTO REPEAT" on the next page for details.

If the tape is slack, the shut-off switches incorporated into the tension arms go to OFF and this stops the tape travel. In cases like this, check the tautness of the tape.

To temporarily stop the tape travel during playback, depress the PAUSE switch.

- You can adjust the tape speed within $\pm 6\%$ of its rating with the pitch control.

5. When playback has finished.

When playback has finished, press the ■ stop button. If the tape has run out during playback, the shut-off switch goes off and the tape deck is automatically set to the stop mode.

- To adjust the sound quality and volume, operate the controls on the stereo amplifier.

AUTO REVERSE

You can automatically reverse the tape from a forward to a reverse direction during playback if you stick the accessory sensing tape onto the magnetic surface of the playback tape. Moreover, you can also reverse the direction of the playback tape from reverse to forward by using the auto repeat mechanism. Finally, you can change over the direction of the tape manually to forward or reverse even during auto reverse by depressing the appropriate PLAY (◀, ▶) button.

- The tape always goes from forward to reverse with automatic reverse which makes use of the sensing tape. It will not go from reverse to forward.

STICKING THE SENSING TAPE (Fig. 15)

1. Use the accessory sensing tape (10 ~ 12mm).
2. Stick the sensing tape onto the magnetic surface of the playback tape exactly where you want it to be automatically reversed. Make sure that the sensing tape does not protrude over the edges of the playback tape. It does not matter if the part of the tape earmarked for the sensing tape is the leader section.
3. Smooth the sensing tape to remove any air bubbles.

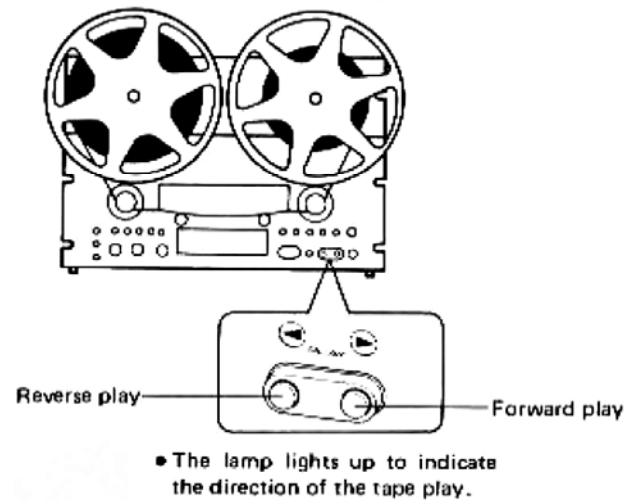

Fig. 14

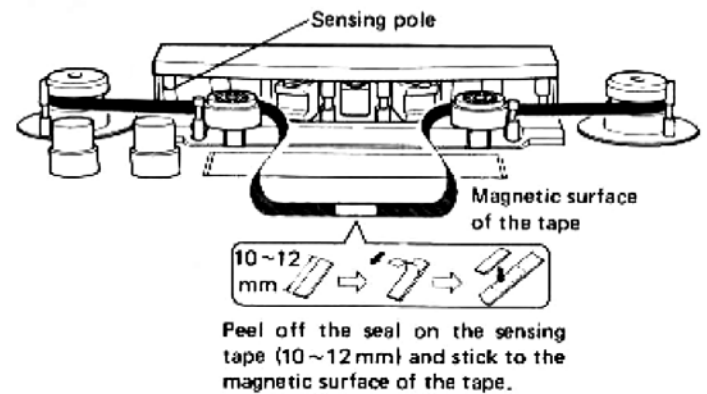

Fig. 15

ADJUSTING THE PLAYBACK SPEED

Using the PITCH CONTROL knob, you can change the tape speed to within $\pm 6\%$ of that speed which has been selected by the SPEED switch (19cm/s, 9.5cm/s). Turning this control to the left from the central position slows down the tape speed and lowers the musical steps. Turning it right round to the left lowers the musical steps by a semitone. Conversely, turning the control to the right, increases the tape speed and raises the musical steps. Turning it fully to the right raises the musical steps by a semitone.

If you listen to the playback sound and adjust this control, you can easily harmonize the musical steps of the music you want to perform.

Normally, this control is kept to the central position during playback.

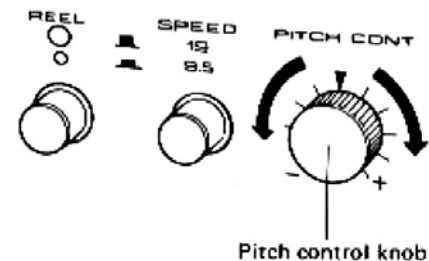

Fig. 16

AUTO REPEAT

You can play back a tape you want to hear again and again if you use the sensing tape and the auto repeat mechanism together. For example, say you want to hear just one tune or song from a group of recorded melodies. All you have to do is to stick the sensing tape onto the playback tape immediately after the melody you want to hear, and then set the auto repeat mechanism at the beginning of the melody. Sit back and you will hear that melody as many times as you want to without lifting a finger.

PROCEDURE FOR AUTO REPEAT

1. Wind the tape onto the right-hand reel by depressing the ►► fast forward button.
2. Stick the sensing tape onto the end of the tape on the right-hand reel.
3. Wind the tape onto the left-hand reel by depressing the ◀◀ rewind button.
4. Depress the forward ► PLAY button and start forward playback.
5. Depress the counter reset button to "0000" at the beginning of the part of the playback you want repeated. Then, depress the REPEAT button.

The tape will continue to run until the sensing tape is reached which will automatically reverse the tape and set the tape in the reverse playback mode. The counter will count down and when it goes down past "0000" to "9999", the tape is reversed automatically and is now played back in the forward direction.

- The tape always goes from reverse to forward with automatic reverse which makes use of the auto repeat mechanism. It will not go from forward to reverse.

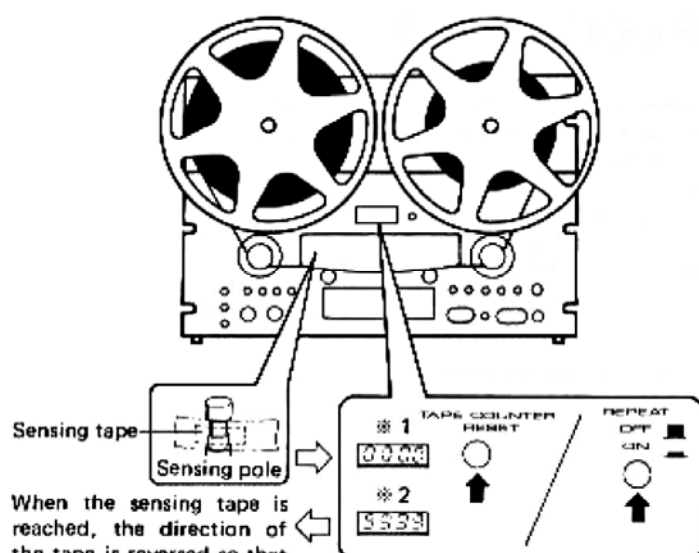

When the sensing tape is reached, the direction of the tape is reversed so that it is played back in the reverse direction.

- * 1 Push this button at the desired position on the tape when the tape is running in the forward direction.
- * 2 The direction of the tape is automatically reversed when the counter reaches "9999" when the tape is running in the reverse direction.

Fig. 17

HOW TO USE THE MONITOR SWITCH

As shown in Fig. 18, the RT-909 adopts an independently aligned erase/reverse playback/recording/forward playback 4-head system.

While you are recording, the erase head goes into action and erases any pre-recordings on the tape before they reach the recording head. This means that you can record a new program source even if you are using a pre-recorded tape. In addition, you can also play back the newly recorded program immediately with the playback heads.

If you set the MONITOR switch to TAPE during recording, you can listen in to the program which has just been recorded. Setting the same switch to SOURCE allows you to listen in to the program which you are about to record and to check whether you want to go ahead and record it or not. Be sure to set the stereo amplifier's TAPE MONITOR switch to ON when monitoring the recording from the stereo amplifier.

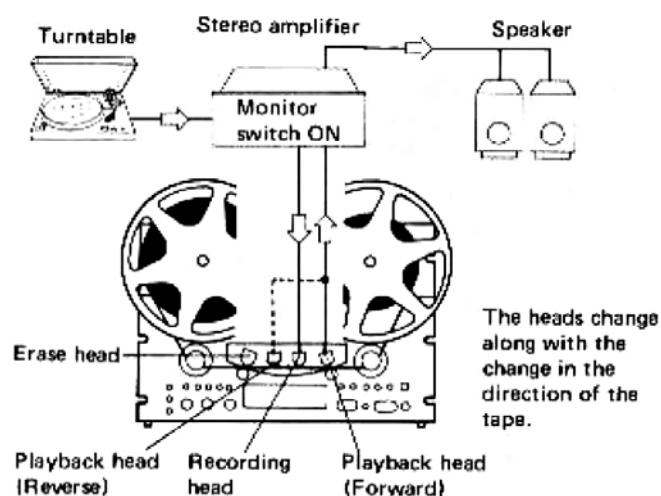

The heads change along with the change in the direction of the tape.

Fig. 18

RECORDING

Before beginning recording, set the controls on the tape deck and the stereo amplifier as follows:

- Set the FL meter switch to AVERAGE.
- Release the REPEAT button and set it to OFF.
- Turn LINE and MIC recording level controls fully to left.
- Set the OUTPUT (Playback level) controls to their center click-stop positions.
- Inspect the heads, the capstans and the pinch rollers and clean them if dirty. (See page 22)
- Release the TIMER START switch and set it to OFF.
- Set the REEL size selector in accordance with the reels you are using.
- If there is any tape slack, rotate the left or right reels and stretch the tape.
- Check connections between RT-909 and stereo amplifier or receiver.

The numbers in the illustration correspond to the steps involved in the recording procedure.

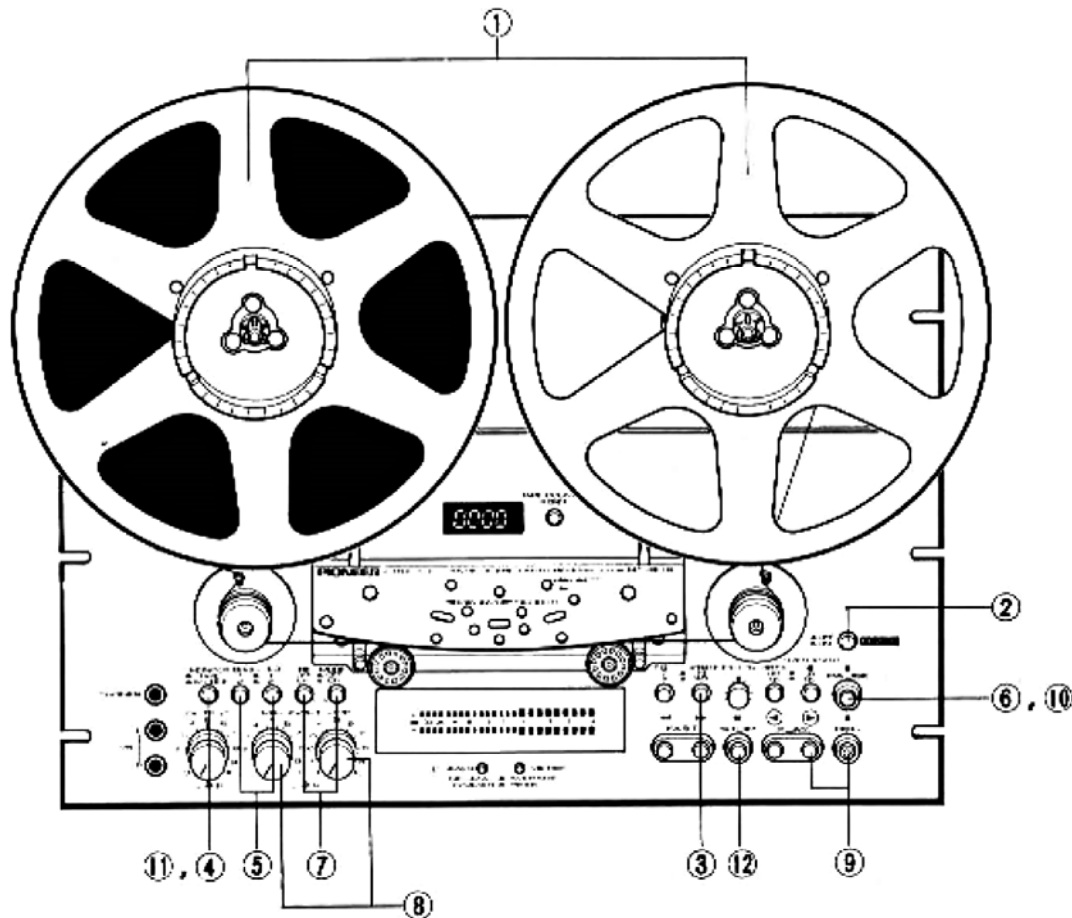

1. Attach the tapes.

Attach the tape you want to record to the left-hand reel base. For details, refer to "THREADING THE TAPE" on page 8.

2. Push POWER switch to turn power on.

The FL meters and tape counter light up and the capstan starts rotating as soon as the power is switched on.

3. Setting the tape speed.

Set the SPEED switch to 19cm/s or 9.5cm/s in accordance with the program source you intend to record.

4. Set the MONITOR switch to SOURCE.

5. Setting the BIAS and EQ switches.

Refer to the section on "Bias and EQ Switches" on page 16 and set the switches in accordance with the type of tape you intend to record on.

6. Press the PAUSE button.

7. Selecting the REC MODE switches (L, R)

Normally, both switches are depressed. However, depress only the L or R switch for mono recordings.

8. Setting the recording level.

The FL level meter lights up to display the input signal level in accordance with the strength of those signals. Refer to "Setting the recording level" on page 15 and adjust the LINE or MIC recording level controls. Unless you are mixing and recording, set the level controls (LINE or MIC) which are not being used to their left-most () positions.

9. Press forward PLAY and REC buttons together.

The recording indicator will light up.

10. Start recording.

Release the PAUSE button. The tape travels from left to right and the deck is set to the recording mode. If there is any slack in the tape, the shut-off switch goes off and the tape stops. Be sure to keep the tape taut.

11. Monitoring the recording.

Set the MONITOR switch to TAPE and compare the sound quality with that when the same switch was set to SOURCE. If there is anything unusual about the sound quality when the MONITOR switch is set to TAPE, this may indicate a deformed tape, a dirty head section or an irregularity in the recording level or BIAS and EQ switches. Track down the cause of the problem and start recording again.

12. When recording is completed.

When the recording is over, press the ■ stop button. If the tape runs out during recording, the tension arm causes the shut-off switch to go off and the tape deck is automatically set to the stop mode.

NOTES:

- Press the PAUSE button if you want to stop the tape temporarily during recording.
- If you depress the ■ stop button during recording and stop the tape, the REC button will be released and the tape deck will be set to the stop mode. To re-start recording, depress both the REC and PLAY buttons again.
- A program cannot be recorded when the tape is traveling in the reverse direction.
- If the reverse ◀ PLAY button is depressed during recording, the deck is released from the recording mode and set to the reverse playback mode.
- Do not set the REC MODE switch during a recording.
- To record a program on the opposite side of a tape, first completely wind up the tape on the take up reel on the right side and then interchange the tape supply reel and the takeup reel. Before removing the reels, be sure to lock the tension arm. Release the lock only after the reels have been changed.

ERASING RECORDED SOUND

- Turn the recording level controls (LINE, MIC) to the left as far as they will go and depress both the REC and PLAY ▶ buttons together if you want to erase completely a previously recorded program source.
- If you want to record a new program source on a tape which has previously been used for recording, the recording is automatically erased and the new program source is recorded instead.

SETTING THE RECORDING LEVEL

If you record a program source at a recording level which is unsuitable, the signal-to-noise ratio of the playback sound will deteriorate and the distortion will increase. Set the level according to the following procedure and safeguard against poor recordings.

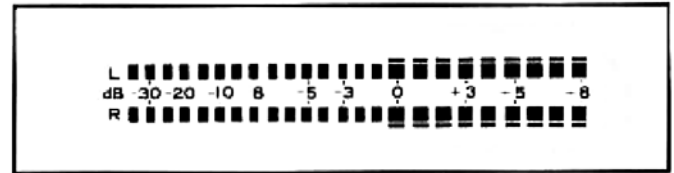

Fig. 19

1. Set the METER switch to AVERAGE.
 2. Adjust the INPUT recording level controls so that the meter display is contained within a -5dB to 0dB range when the program source has relatively high signal strengths.
 3. Set the METER switch to PEAK.
 4. Re-adjust the INPUT recording level controls so that the meter display does not continuously exceed +5dB.
 5. Set the METER switch to AVERAGE and re-adjust that the meter indication is less than 0dB.
- If you record a sound source when the meter indication exceeds full scale, the playback sound will be distorted. Conversely, if the meter indication is too low (-30dB to -20dB), the signal-to-noise ratio will deteriorate and you will hear a great deal of noise when you play your recording back.
 - If you adjust the recording level merely on the basis of the peak signal indication, the recording level will be set too low since you have adjusted it with the maximum input signal value. As a result, the signal-to-noise ratio will be downgraded.
 - The signal level will fluctuate widely according to the program source, and so keep observing the meter indication while you are recording.

PEAK METER AND LEVEL METER

The peak meter can cope more sensitively with sudden peak inputs than the level meter can. The level meter serves almost to simulate your sense of hearing, and it indicates the average strength of the input signals. Naturally, the peak input signal which is recorded has a higher level than the average level and so the standard '0dB' level meter level is set lower than the saturation level of the tape. The peak meter is constructed so that its very fast response speed indicates peaks even if pulse-like signals are included in the input signals. When performing live recordings or when recording sources with a great many peak portions, make use of the peak meter and you will then ensure that the sound will not be distorted at the peak level.

BIAS AND EQ SWITCHES

BIAS switch

In order for the tapes to give full rein to their characteristics and for you to keep distortion to the minimum, you must select a bias value in keeping with the characteristics of the tape you are using.

- If you record an LH tape with the BIAS switch set to 1, the bias becomes shallow, distortion increases and the high range level rises resulting in an unnatural sound.
- If a standard tape is used with the switch set to 2, the bias deepens and so the high range level drops.

EQ switch

Standard and LH tapes have different equalization values in the high range during recording and so you must not only choose a bias value in keeping with the characteristics of the tape, but also make allowances for high range equalization. Set the EQ switch in accordance with the characteristics of the tape you are using.

- If you record an LH tape with the switch set to 1, the high range level rises, resulting in an unnatural sound.
- If you record on a standard tape with the EQ switch set to 2, the high range level drops.

BIAS and EQ switch combinations with different makes of tape

Table 1 lists the standard combinations of the switches and tapes although the two switches allow a total of four combinations.

The table does not aim to give you absolute values. Feel free to press and release the MONITOR switch and compare the sound at TAPE with that at SOURCE. Set the switches so that the sound is to your liking.

(Before choosing the 1 and 2 positions, read the tape's 'instructions for use').

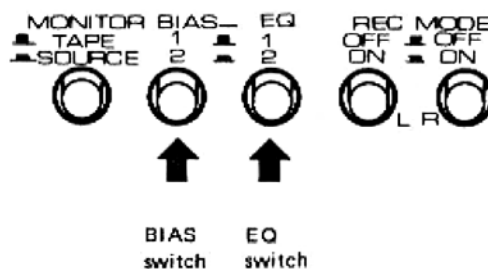

Fig. 20

Major Tape Brands & BIAS, EQ Switch Settings

Table 1

Leading bands of tapes		BIAS switch		EQ switch	
		1	2	1	2
SCOTCH	206, 207, 218, 228		○	○	
	229 CLASSIC		○	○	
	211, 212, 213	○			○
SONY	SUPER	○		○	
	SLH, DUAD		○		○
TDK	T-555	○		○	
	SD-150, AUDUA		○		○
MAXELL	UD-50, UD-35, LN-50		○		○
AGFA	PER-525, PER-555		○	○	
	PE-36, PE-46	○			○
BASF	LH PROFESSIONAL		○		○
	LP-35LH		○		○
AMPEX	434, 444		○	○	
	406, 407		○	○	

- The bias values indicated in the table are not absolute values, but are the values which have been determined for the RT-909 tape deck.
- If the desired quality of sound cannot be obtained with the bias and EQ controls set as indicated in the table, change the settings until the desired quality is obtained.

MICROPHONE RECORDING

STEREO RECORDING

Connect either a stereo microphone or two identical models to the MIC jacks (L and R), as shown in Fig. 21. For the recording procedure, refer to the section on "Recording" on page 14.

Points to bear in mind

- You can use either low impedance (600-ohms) or high impedance (10 – 50-kohms) microphones.
- If you are using a high impedance microphone, make sure that its cable is not more than 5 meters long.
- When not recording with microphones, either pull the microphone plugs from the MIC jacks or set the MIC switches to OFF.
- When using a microphone to record, it's a good idea to monitor the recording through your headphones.
- Monitoring the recording with the speakers very often gives rise to howl so use the microphone as far away from the speakers as possible.

MIXING RECORDING

You can mix the signals from the MIC input jacks with those of the line input (INPUT) terminals.

1. Connect the microphone plug (or plugs) to the MIC jack (or jacks), and then connect the signals from the stereo amplifier to the INPUT terminals.
2. You can adjust the microphone signals with the MIC recording level controls. The signals from the stereo amplifier can be adjusted using the LINE recording level controls.
3. Refer to the section "Recording" on page 14 or the recording procedure.

NOTES:

1. Set the recording level controls not used for mixing at their lowest level (turn right round to the left).
2. You will obtain much better results with mixing if you turn the LINE recording level controls down slightly rather than if you use the microphones or line input independently.

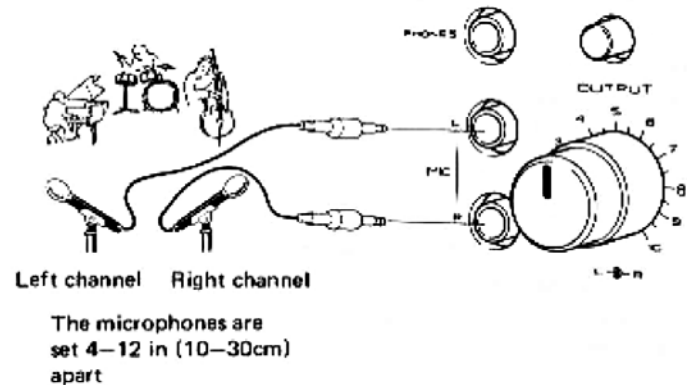

Fig. 21

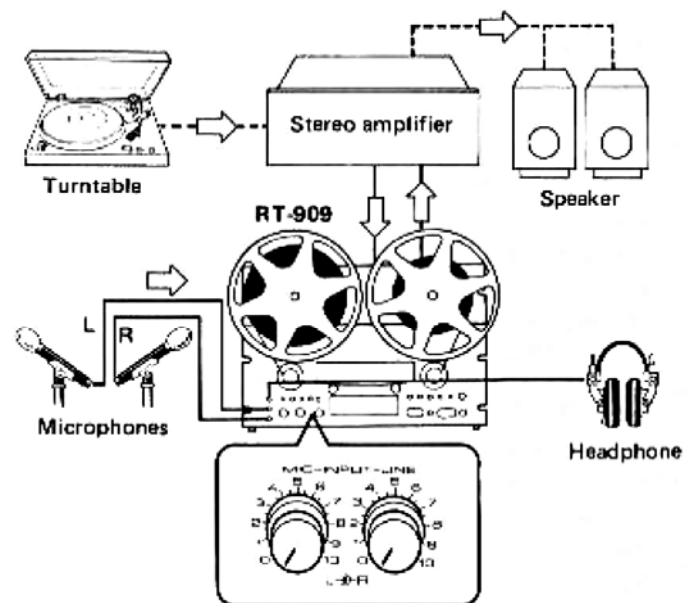



Fig. 22

OTHER METHODS OF RECORDING

SOUND-ON-SOUND RECORDING



Sound-on-sound is one method of recording you can pursue. It briefly involves mixing a fresh program source with the sound being played back on a monaural recorded tape. The new sound source is mixed and recorded on a different track. Let's take an example: you can all by yourself sing a duet or trio accompanied by background music which is played back as you sing.

L channel playback, R channel recording

1. Connect the R INPUT terminal with the L OUTPUT terminal on the rear panel of the RT-909. (Refer to Fig. 23).
2. Connect the microphone to the R MIC jack on the front panel.
3. Depress the R REC MODE switch (ON position) and release the L switch (OFF position).
4. Depress the TAPE MONITOR switch (TAPE position).
5. Depress both the forward  PLAY and REC buttons.
6. Using the LINE and MIC recording level controls, adjust the levels of the playback sound and microphone sound. Should the playback level be high, adjust with the L channel output level control.
7. Rewind the tape to start position, then start the microphone recording, all the while listening to the L channel playback sound through the headphones. Table 2 shows the differences in the lighting indication of the fluorescent (FL) tube level meter during recording and in the OUTPUT terminal signals based on the positions of the MONITOR switch.

FOLLOW-UP RECORDING

You can record a new program source as you play back a previously recorded program source.

1. Connect the signals from the new program source to the INPUT terminals or MIC jacks.
2. Adjust the recording level.
3. Depress the forward  PLAY button and set the tape to the playback mode. When a portion of the tape where a recording is to be continued comes, depress the PAUSE button and set the deck to the recording standby mode.
4. Depress the forward  PLAY button and the REC button together and adjust the recording level with the INPUT (LINE or MIC) recording level controls.
5. Depress the PAUSE button again and start recording the new program source.

NOTE:

The tape deck will not be set to the recording mode if you press just the REC button. You must press the PLAY button too.

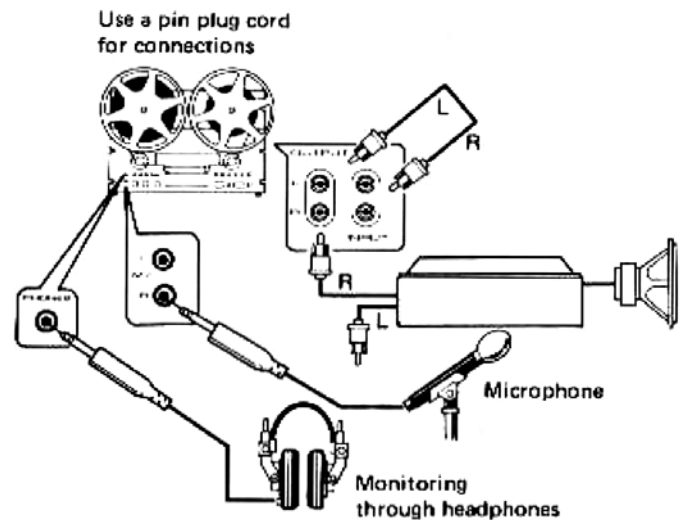

Fig. 23

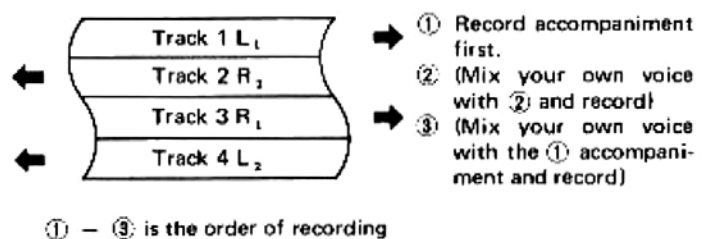



Fig. 24

NOTE:

If you are planning R channel playback and L channel recording, carry out the above steps substituting L for R and R for L. For example, if you record a duet on the R channel by the sound-on-sound method, and then go further to record the R channel playback sound and the fresh program source on the L channel, you will end up with a song in trio. You can keep on repeating the program source in this way for as many superimposed recordings as you like.

Meter pointer deflections and output signals

Table 2

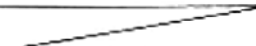
MONITOR switch	Channel	Level meter	OUTPUT terminal
TAPE	LEFT	Lighting indication	Already recorded signals
	RIGHT	Lighting indication	Signals just recorded
SOURCE	LEFT		
	RIGHT	Lighting indication	Signals for recording

LENGTHY MONO RECORDINGS

When the program source does not require recording in stereo, you can still make efficient use of all the tape tracks by recording in mono.

Operation

First, connect the program source to the L (or R) MIC jack, or to the L (or R) REC terminal.

Then:

1. Depress the L (or R) REC MODE switch (ON position) and release the R (or L) switch (OFF position).
2. The sound is recorded on track 1.
3. Stop the tape before it is wound onto the right-hand reel.
4. Change over the reels — the recorded reel should now be on the left and the empty reel on the right. Do not rewind with the tape in the state outlined under (3).
5. When recording starts up again, the sound is recorded onto track 4.
6. Next, re-connect the recording signals to the R (or L) channel and switch the REC MODE switch over. Record exactly as before.

- For playback, refer to Section "Auto Repeat" on page 13. Remember that different signals enter into the L and R channels and so turn down the unnecessary sound with the volume control on the amplifier which you are using for playback, and face it out.

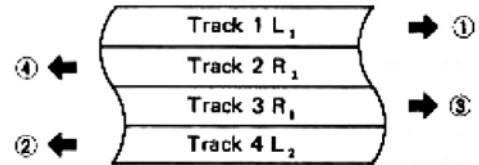

- ① Recording signals: L channel
- ② (Turn tape over to second face) Recording signals: L channel
- ③ (Turn tape over to first face) Recording signals: R channel
- ④ (Turn tape over to second face) Recording signals: R channel
- ① - ④ indicates the order in which the tracks are recorded.

Fig. 25

RACK-MOUNTING

The front panel of the RT-909 is designed to conform to EIA standards. The mounting dimensions are 8U (including blank panels) for the panel size.

Use a rack which meets EIA standards.

MOUNTING PROCEDURE

1. Remove the two feet of the RT-909 with a medium-sized Phillips head screwdriver (see Fig. 26).
To prevent electric shock, the removed four Yellow Colored screws must be screwed back to original position after removed the two feet.
2. Lay the rack down on the floor so that the part of the RT-909 to be mounted faces upward.
3. Determine the mounting position and align the front panel mounting holes with the rack holes. If there is a gap above the panel, determine the mounting position along with the blank panel.
4. Anchor the front panel to the rack with the six mounting screws (accessory to rack). (See Fig. 27)
5. When mounting the blank panel, anchor it to the rack with the two mounting screws (accessory to rack).

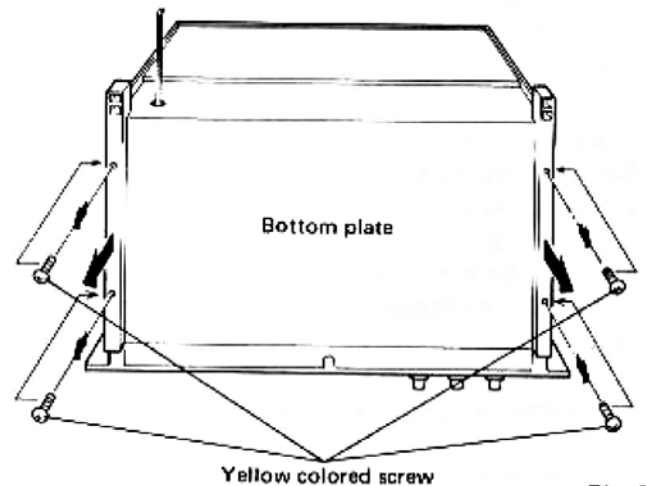

Fig. 26

MOUNTING PRECAUTIONS

- Make sure that the rack is standing on stable ground.
- Keep the rack steady when mounting a component. Make sure that the heavy components are mounted in the bottom part of the rack.
- The inside temperature of unit tend to rise when unit is mounted to the rack and so keep the space (more than 1 inch) in all faces or use a fan for ventilation.

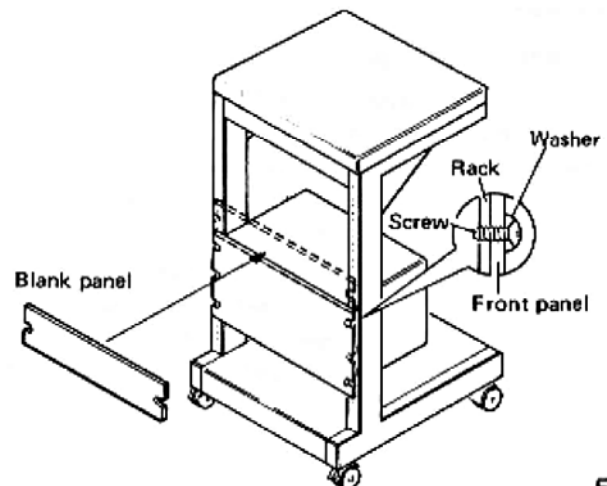

Fig. 27

OPERATIONS WITH THE TIMER

The Timer switch which is sold separately, allows you to record while you are out or sleeping, or it can wake you up by playing back a recorded program source. It also has a 'sleep' function.

Before unattended recording or wake-up playback

- Check that the tape is wound up on the left reel. Unattended recording starts with the tape traveling in the forward direction just like with normal recording. If the tape is not on the correct reel, depress the REW (◀) button and rewind the tape.
- The tape will not start at the preset time on the timer if the tension arms are locked. Make absolutely sure that you release the lock.

Unattended Recording

1. As shown in Fig. 28, connect the RT-909's power cable to the Time switch. Also, plug the power cables of the stereo amplifier and tuner into the timer so that their ON-OFF functions are controlled by the timer.
2. Set the power switches of the RT-909, amplifier and tuner to ON.
3. Adjust the amplifier controls and tune the tuner into the station whose program you want to record.
4. Follow the steps in section "Recording" on page 14 and proceed with recording. Set the recording levels.
5. Set the Timer switch so that the power will go on at the pre-determined time. The power to the other components goes OFF.
6. Press the TIMER START and REC MODE switches and check that the tape deck will be set to the recording mode when the power goes on.
At the pre-determined time the power will automatically go on and the tape deck will start to record. The Timer switch will also turn the power off again at a pre-arranged time. You can therefore record programs while you are out — just follow the above steps and put your mind at ease.

Sleep Function and Wake-up Playback

1. Connect the power cables of the RT-909 and the stereo amplifier to the Timer switch.
2. Set the timer so that the power goes off in 30 — 60 minutes. You can now relax and listen to music while you fall off to sleep (sleep function).
3. If the timer is set so that the power goes on at the preset time, set the RT-909's POWER switch and the TIMER START switch to ON, and the tape will be played back at the preset time. Make absolutely sure that the REC MODE switch is at the OFF position.

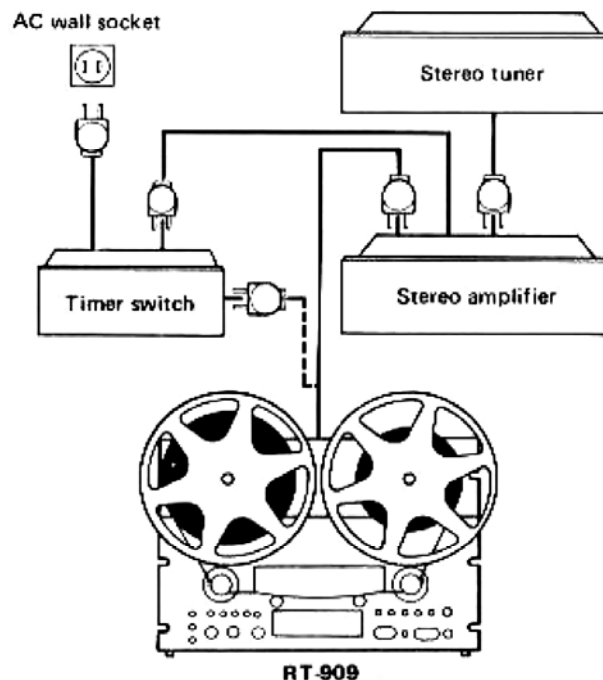

Fig. 28

NOTES:

- If the reverse (◀) PLAY, STOP, fast forward or rewind button is depressed while the TIMER START switch is at ON, the mode corresponding to the depressed button is given priority. However, if the power is switched off in this state and then switched on again by the timer, the timer start operation will begin.
- With the wake-up playback, tape speed is fixed to the reference speed as same as the recording mode, so you can not change the tape speed even when you turn the pitch control knob. When you want to change the tape speed, first depress the stop button and depress the play button, then turn the pitch control knob.

HANDLING TAPES

If your tape has broken, you can mend it with the accessory splicing tape by carrying out the following steps.

1. As shown in Fig. 29, overlap the two ends of the broken tape and cut across them at an angle of about 60 degrees.
2. Prepare a 25mm long piece of splicing tape.
3. Put the reverse sides (the sides that do not come into contact with the heads) on a flat surface and align the two ends of the tape.
4. Hold the splicing tape ends tightly and attach the splicing tape.
5. Smooth the tape to remove any air bubbles.
6. Cut off any splicing tape which protrudes beyond the width of the tape.

NOTES:

- Use a cutting instrument which is not magnetic.
- Splice the broken ends together along the break if you are splicing a pre-recorded tape and you do not want to lose any of the recording by overlapping the ends.

HINTS ON HANDLING TAPES

- Do not use tapes which are creased, curled or have stretched edges. Also avoid using old tapes. Not only is their noise level high, but they may also damage the heads.
- Rewind new tapes and tapes that have not been used for some time before you record on them. Long-term storage accentuates the shape of the tape windings, and downgrades tape-to-head contact, thereby making it impossible to record high-fidelity sound.
- Never touch the upper (magnetized) side of the tapes since this is the cause of drop-outs in recorded sound.

TAPE STORAGE

- Tapes should not be stored after rewinding or fast forward operations which may deform the tape. Store only after winding at the regular playing speed.
- Do not store the tapes in very hot or humid locations. Also avoid areas with magnetic fields like the tops of television sets and amplifiers.
- When you have not used a tape for some time, rewind it from time to time to safeguard against 'print-through' (the signal recorded on one layer of tape is partially copied onto the two adjacent layers).

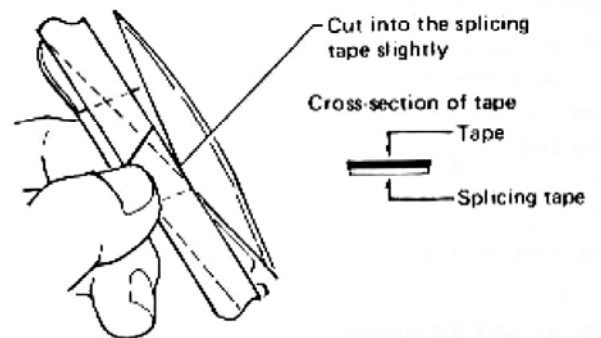
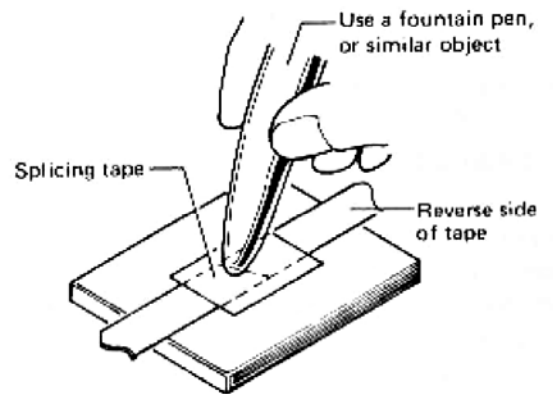
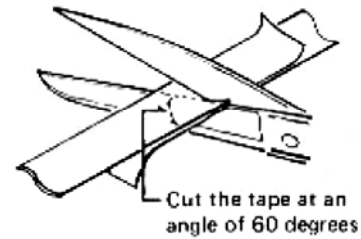

Fig. 29

CARE AND MAINTENANCE

The RT-909 is made up of precision mechanisms. Bear in mind the points below so that you maintain your model in tip-top condition.

CLEANING THE HEADS AND TAPE PATH

Dust, grease and other foreign matter picked up during tape play have a habit of sticking to the heads, tape guides, tension arm, pinch roller, capstan and guide roller (see Fig. 30). In particular, dirt on the heads downgrades tape-to-head contact, sound quality and stereo balance. It is also the cause of unstable operation. To eliminate these problems, make it a habit to clean the heads and the surrounding tape path regularly with commercially sold cleaning swab or with cleaning fluid applied to a soft cloth (see Fig. 30).

CLEANING THE PANELS

Wipe the panels and casing when dusty or dirty with a polishing cloth or a dry cloth. If very dirty, dilute ordinary washing-up liquid to 5–6 times its normal strength, dip a soft cloth into the liquid and apply lightly. Then wipe with a dry cloth. Do not use furniture wax or cleaner. Do not use volatile chemical spirits like thinners, benzine and alcohol because they will damage the heads and the housing.

DEMAGNETIZING THE HEADS

The recording head becomes magnetized when you use the tape deck over prolonged periods of time. This results in noise being generated and the treble dropping off during recording or playback. The recording head should therefore be regularly demagnetized with the head eraser which is sold separately. For further details, read through the head eraser's 'instructions for use.'

NOTE:

Do not hold screwdrivers, metal objects or magnets close to the tape head.

REC AZIM and PLAY AZIM adjusting screws

Both PLAY AZIM (playback azimuth) screws and the REC AZIM (recording azimuth) screw are adjusted before the tape deck is shipped from the factory.

Do not adjust these screws unnecessarily since this may impair the quality of the sound.

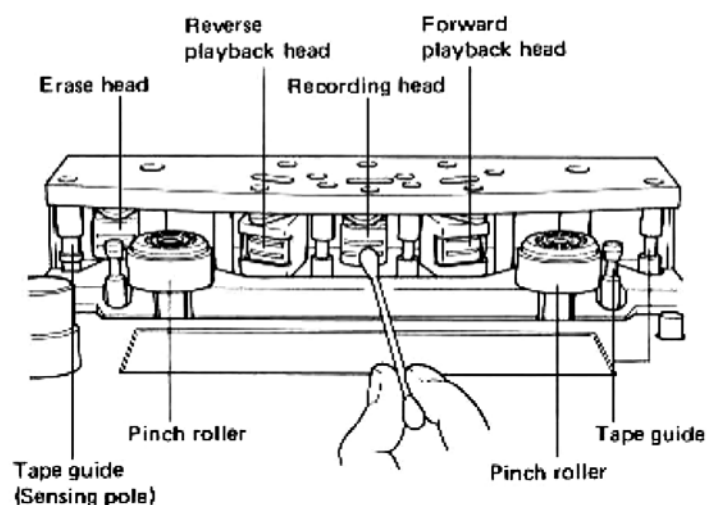

Fig. 30

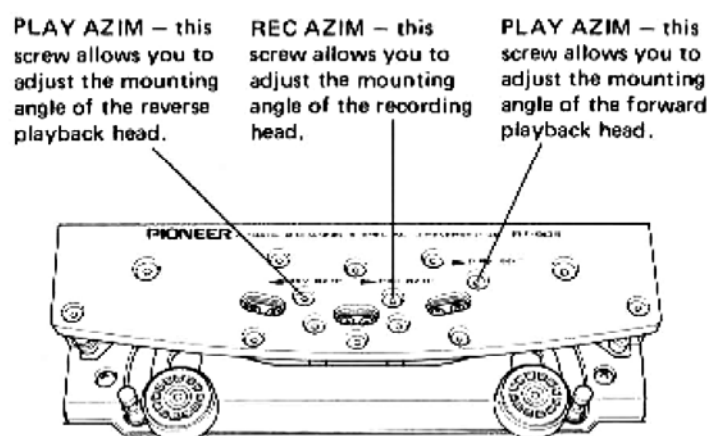

Fig. 31

SPECIFICATIONS

Type	4-track, 2-channel stereo tape deck (Recording, forward playback with reverse playback)
Operation system	Solenoid drive, direct switchable function buttons and pre-set function buttons for timer recording and playback.
Heads	Hard permalloy recording head ; 1 Ferrite erasing head ; 1 Hard permalloy forward playback head ; 1 Hard permalloy reverse playback head ; 1
Motors	Capstan drive motor ; 1 {FG Servo DC motor} Reel base drive motors ; 2 {6-pole inner-rotor special induction type}
Maximum Reel Size	10-1/2-inch reel (26cm)
Tape Speed	19cm/s {7-1/2ips}, 9.5cm/s {3-3/4ips} ±0.6%
Fast Forward/Rewind Times	Less than 120sec. with 10-1/2-inch reel and 720m tape
Wow and Flutter	No more than 0.04% WRMS (19cm/s) No more than 0.08% WRMS (9.5cm/s)
Signal-to-Noise Ratio	More than 60dB
Total Harmonic Distortion	Less than 1% (19cm/s)
Frequency Response	
19cm/s	20Hz to 30,000Hz (20Hz to 28,000Hz ±3dB)
9.5cm/s	20Hz to 20,000Hz (20Hz to 18,000Hz ±3dB)
Crosstalk	More than 50dB
Channel Separation	More than 50dB
Erasing Coefficient	More than 60dB
Recording Bias Frequency	125kHz
Equalization	NAB standards
Inputs {Sensitivity/Maximum allowable level/Input impedance}	
MIC x 2: 0.316mV/100mV/27kΩ, 6mm diam. jacks (suitable microphone, 250Ω to 10kΩ)	
LINE x 2: 50mV/25V/50kΩ	
Outputs {Reference level/Maximum level/Load impedance}	
LINE x 2: 450mV/900mV/50kΩ, HEADPHONES x 1: 50mV/8Ω, 6mm diam. jack	
Semiconductors	123; transistors (4; FET's, 43; IC's, 111; diodes (including 5; LEDs and 6; zener diodes) 2; Photo Interrupters.

Accessory Functions

- Automatic repeat play (Automatic reverse)
- Fluorescent display level meter with peak/average switch (-30dB to +8dB)
- 4-digit fluorescent tape counter
- Height-adjustable reel base
- Timer aid recording/playback device
- Pause switch
- Independent Bias/EQ selectors
- Pitch control (±6% only in playback mode)
- MIC/LINE mixing
- Add-on recording
- Independent Left/Right recording mode switches
- Output level control (clicked for reference level; Left/Right Coupled)

- Reel clamps
- Dimmer switch
- EIA rack mounting

Power Requirements	AC 120V 60Hz
Power Consumption	166 watts, Max. (ULI)
Dimensions	480(W) x 340(H) x 318(D)mm 18-7/8 x 13-3/8 x 12-1/2in
Weight	Without package; 21 kg/46lb 5oz With package; 25.5kg/56lb 4oz
Accessories	<ul style="list-style-type: none"> ● 10in metal reel (Pioneer PR-101) x 1 ● 10-1/2in reel adapters x 2 [PP-220] ● Connecting cord with pin plugs x 2 ● Sensing tape x 1 ● Splicing tape x 1 ● Operating instructions x 1 ● Blank panel x 1

Note:

Specifications and the design subject to possible modification without notice due to improvements.

Dimensions

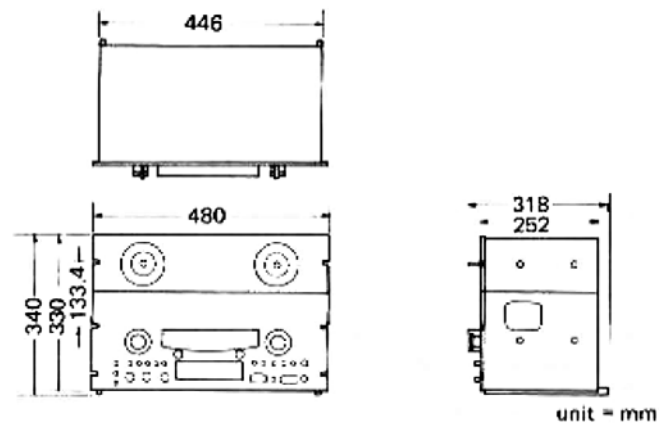

Test Conditions:

1. Reference tape: Scotch #206
2. Reference recording level: meter 0dB level (NAB standard reference level)
3. Reference signal: 1,000Hz
4. Wow & Flutter: at 3,000Hz weighted RMS
5. Frequency response: measured at -20dB level (19cm/s)
6. Signal-to-Noise ratio: measured at the signal level where 3rd harmonic distortion is 3%, and noise level is corrected by A curve.
7. Total Harmonic Distortion: measured at reference recording level
8. Channel separation: measured at reference recording level
9. Channel crosstalk: measured at 0dB level (reference recording level)
10. Sensitivity: Input level (mV) for reference recording measured with input (recording) level control set at maximum position.
11. Maximum allowable input level: measured at the point where the output signal wave is clipped while gradually turning the input control.
12. Reference output level: meter 0dB level.
13. Maximum output (playback) level: Output level to reference recording level, measured with output (playback) level control set at maximum position.

TROUBLESHOOTING

Failures and breakdowns can be traced to mechanical defects or they may appear to be caused by such, but are in fact the result of improper maintenance, tape defects or lack of experience in operating the tape deck, since the symptoms are quite often the same. Before contacting the serviceman, check the following points.

Symptom	Cause	Remedy
1. Power does not go on.	Power cable is not connected properly.	Check power cable connection.
2. Tape does not run properly.	a. Tape is slack. b. The size of the left and right reels is not identical.	a. Pull tape taut. b. Use reels of the same size.
3. Deck fails to rewind.	a. Size of reels differs greatly. b. REEL size selector position is incorrect.	a. Use reels of the same size. b. Set in accordance with size of reels being used.
4. Noise is generated (great deal).	a. Connecting cables are not connected properly. b. Noise is on tape. c. External induction. d. Head is magnetized.	a. Check the connections. b. Replace with a good-quality tape and compare results. c. Do not use deck near TV, amplifier, fluorescent lights, etc., since these cause induced noise. d. Demagnetize head with head eraser.
5. Sound drop-out.	a. Heads are dirty. b. Tape is dirty. c. Tape is deformed.	a. Clean the front of the heads with a cleaning fluid which you can buy from your audio dealer. b. } c. } Replace tape with good-quality tape.
6. Playback sound is unnatural. (Poor sound quality, distortion, extraneous noise etc.)	a. Heads are dirty. b. Incorrect tape speed. c. Tapes have different track configuration.	a. Clean front of heads with commercially sold cleaning fluid. b. Adjust to correct tape speed. c. Replace tapes.
7. Deck fails to record (level meter pointers do not deflect, either).	Connecting cables are not connected properly.	Check INPUT (REC) terminals.
8. Distortion in recording.	a. Input level is too high. b. Recording level is too high. c. BIAS, EQ switches are incorrectly set.	a. When tuner or amplifier output level is too low, adjust while maintaining recording level controls at central position. b. Re-adjust recording level. c. Set switches properly in accordance with characteristics of tape.
9. Sound in high frequencies is unsatisfactory.	a. Heads are dirty. b. BIAS, EQ switches are incorrectly set.	a. Clean front of heads with cleaning fluid. b. Set switches properly in accordance with characteristics of tape.

Moisture forms in the operating sections of this model and the model's performance will be impaired if the model is brought from cool surroundings into a warm room or if the temperature of the room rises suddenly.

To prevent any performance impairment, let the model stand in its new surroundings for about an hour before switching it on, or ensure that the room temperature rises gradually.

PIONEER ELECTRONIC CORPORATION

4-1, Meguro 1-Chome, Meguro-ku, Tokyo 153, Japan

U.S. PIONEER ELECTRONICS CORPORATION

85 Oxford Drive, Moonachie, New Jersey 07074, U.S.A.

PIONEER ELECTRONIC (EUROPE) N.V.

Luthagen-Haven 9, 2030 Antwerp, Belgium

PIONEER ELECTRONICS AUSTRALIA PTY. LTD.

178-184 Boundary Road, Braeside, Victoria 3195, Australia

Printed in Japan